

HOFMANN®



Geoliner 650

IMAGE WHEEL ALIGNER

Set-Up To Readings In Under 2 Minutes

- Do more alignments in less time
- So easy to use that technicians will actually sell more alignments
- Improves revenue with higher productivity
- Non-electronic shatter-proof wheel sensor targets eliminate calibrations, wheel sensor maintenance and cables
- No comebacks due to calibration problems



1

Mount wheel targets



2

Roll vehicle back or pull forward only 8"

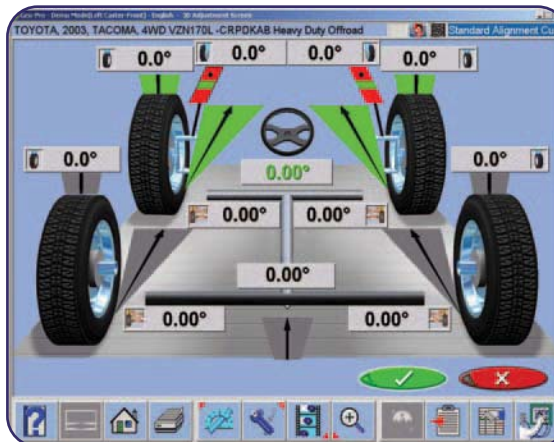

3

Obtain all alignment readings in under 2 minutes. Adjust vehicle using live measurements.



VEHICLE ORIENTATION DIRECTIONAL INDICATOR

Multi-Processor Cameras*

VODI™* Graphic Display - Graphic overlay around each camera provides visual and directional assistance to the operator during the alignment measurements.

Tires represent (4) targets.

GREEN LED indicates target found.

RED LED indicates target missing.

Left and Right direction arrows illuminate indicating direction wheels are turning during Caster and Turning Radius measurements.

Up and Down direction arrows illuminate indicating vehicle movement direction during Positioning/rollback.

All 4 arrows illuminated indicate **STOP**.

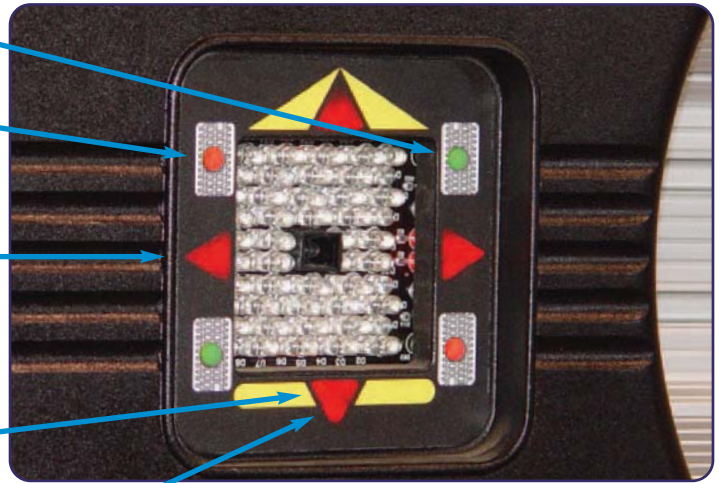

25" UNIVERSAL WHEEL CLAMPS

Heavy duty chrome rods and nickel-plated screw

Thin profile tip fits most wheel/tire combinations.

Extended tip with thin profile allows clamping over plastic wheel covers.

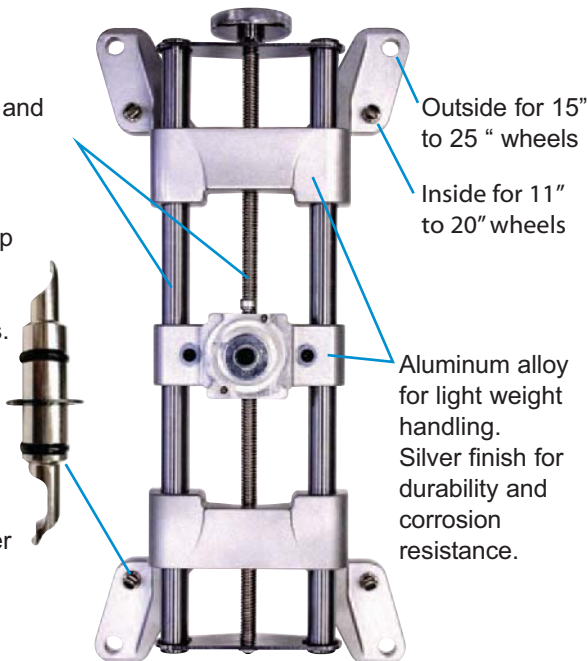

Outside for 15" to 25" wheels

Inside for 11" to 20" wheels

Aluminum alloy for light weight handling. Silver finish for durability and corrosion resistance.

Tire Clamp Adapter

(EAK0268J63A) allows accurate clamping without risk of scratching the wheel finish. Tire clamps provide secure attachment to wheel while plastic sleeves placed over standard claws ensure proper placement and wheel protection.

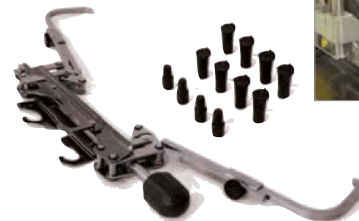

Optional Clamp Extensions

(EAK0268J62A) increase maximum clamping diameter to 30 inches.



Geoliner 650

HOFMANN®



**Windows® based Image Technology with both speed
and accuracy for the automotive professional**

FEATURES

Alignment Display

- Front Readings
- Rear Readings
- All Readings
- Zoom Readings
- Individual Camber
- Individual Toe
- Individual Caster
- SAI & Thrust Angle
- Included Angle
- Front & Rear Setback
- Toe Out On Turns
- Front Caster (-28° to +28°)
- Front & Rear Camber (-15° to +15°)
- Front & Rear Toe

Meter And All Reading Screens

- Advanced Alignment Measurements with reading/specifications and cross values
- Meter Screens
- Live 3-D Modeling*

System Controls

- Remote control
- Console keyboard
- Optical Mouse

Other Software Features

- 3-D Animation
- Live Video Helps (Multimedia)
- Multiple A-Arm Adjust
- Adjust Camber Only

(Other Software Features continued)

- Elevated Adjustments
- Rear Shim Programs
- Adjustment Help Files
- E-Z Track Data Base
- Align Specs -30 years
- E-Z Toe
- Ride Height Charting

Additional Setups

- 28 Languages
- Multiple Print Formats

SPECIFICATIONS

Computer Alignment Systems

- 17" color display monitor
- Mobile cabinet
- State-of-the-art Dell® PC
- DVD drive / 3.5 floppy
- Network card
- Color Ink Jet Printer
- Wheel Clamps
- 3-D Animated graphics

Standard Accessories

- Steering wheel holder
- Brake pedal depressor
- Optical Mouse

Optional Equipment

- Stainless steel turntables 054
- Rollback Kit for Stainless turntables 055
- Roll Forward Kit for 4-post 056
- Stainless Turntables (Hunter/Rotary) (Set: 2) 89261
- Roll Back Kit (Rotary) 89327
- Roll Back Kit (Hunter) 89328
- Adjustable height camera boom EAA0321J19A
- Fixed camera 1-post support EAA0321J01A

Accessories

- Alignmt Conversion Kit for use w/ 43102 lifts 053ALN
- Heavy Duty Truck Turntables, (Set: 2) 1260
- Surface Mount Portable Rear Slip Plates, (Set: 2) 64222
- Frame Angle Gauge 8-05320A

(Accessories Continued)

- Clamp Extensions (up to 30") EAK0268J62A
- Tire Clamp Adapter EAK0268J63A
- Remote Display Readout w/ 30" cable EAK0268J08A
- Rollback Rubber Pads, (Set: 2) 046
- Convex Mirror 36" wide w/ hardware P-1826

Equipment Specifications

- Wheel size: 11" - 25"
- Tire diameter: unlimited
- Tread width: 48" - 96"
- Wheel base: 79" - 200"

Power Requirements

- 115V / 1Ph, 50/60 Hz / 6 amp
- 230V / 1Ph, 50/60 Hz / 3 amp

* Patented and/or Patent Pending Features

HOFMANN®
USA



309 Exchange Avenue • Conway, AR 72032
(800) 251-4500 • (501) 450-1581
Fax (501) 450-2085 • www.hofmann-usa.com

HOFMANN®
Canada



6500 Millcreek Drive • Mississauga, ONT L5N 4G4
(800) 267-2185 • (866) 812-5316
Fax (905) 821-2073 • www.hofmann.ca
E-mail: info@hofmann.ca